

Mixture separation

Part 1 – Drawing scientific equipment

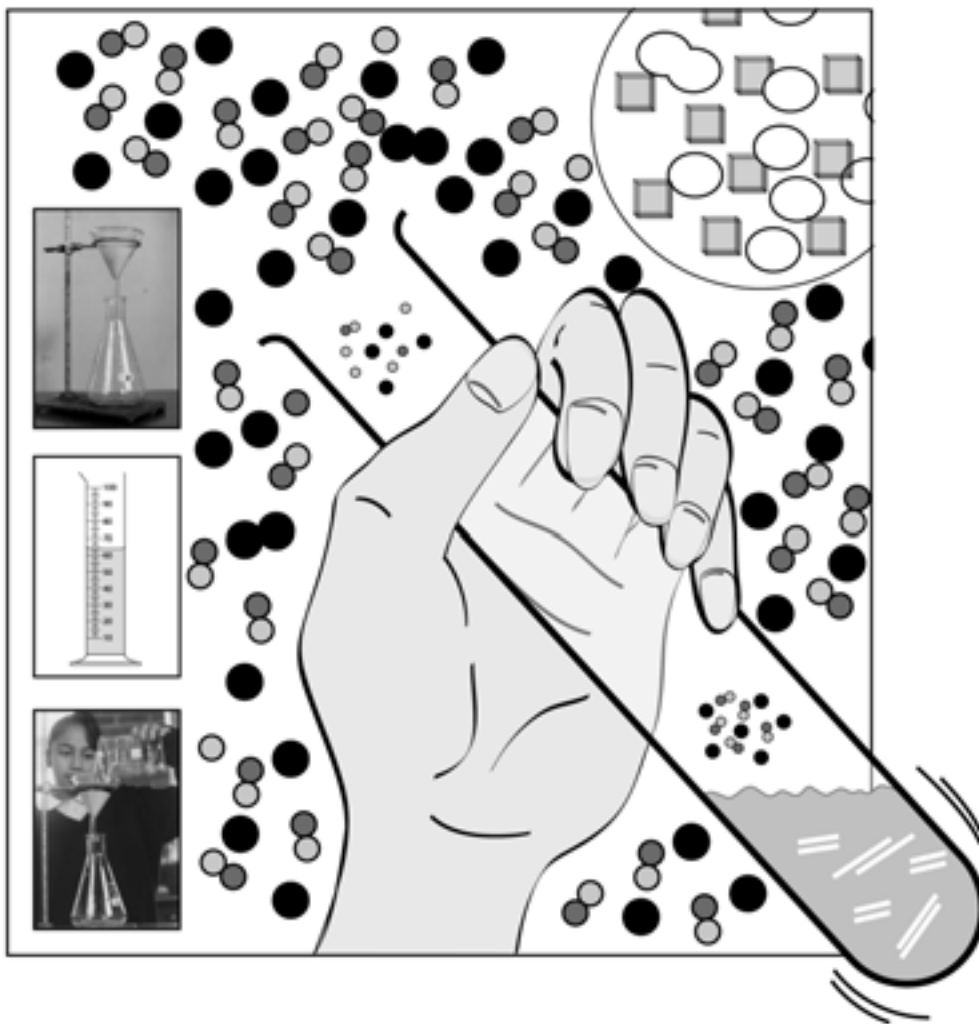

Number: **43922**

Title: **Mixture Separation**

This publication is copyright New South Wales Department of Education and Training (DET), however it may contain material from other sources which is not owned by DET. We would like to acknowledge the following people and organisations whose material has been used:

Extract from *Science Syllabus* Years 7-10 © Board of Studies, NSW 2003

Overview
pp iii-iv

Screenshot of drawing toolbar from Microsoft Word used by permission from Microsoft Corporation.

Part 1, p19

CLI Project Team acknowledgement:

Writers: Sue Doolan and Richard Alliband
Editors: Julie Haeusler and Rhonda Caddy
Illustrators: Quan Pham and Sue Doolan

All reasonable efforts have been made to obtain copyright permissions. All claims will be settled in good faith.

Published by
Centre for Learning Innovation (CLI)
51 Wentworth Rd
Strathfield NSW 2135

Copyright of this material is reserved to the Crown in the right of the State of New South Wales. Reproduction or transmittal in whole, or in part, other than in accordance with provisions of the *Copyright Act*, is prohibited without the written authority of the Centre for Learning Innovation (CLI).

© State of New South Wales, Department of Education and Training 2005.

Contents – Part 1

Lesson 1: Scientific drawing	3
Lesson 2: Scientific drawing of laboratory equipment	5
Lesson 3: Labelling diagrams	13
Lesson 4: Drawing and labelling a scientific diagram	17
Lesson 5: Computer graphic skills using <i>MS Word</i>	19
Suggested answers – Part 1	23
Exercises – Part 1	27

Lesson 1: Scientific drawing

Have you ever thought about how people communicate? Mostly people use a language to speak and to write messages. The words in a language are a sort of code. Each word stands in place of an object or an idea.

Scientists often use codes to communicate. Later in your science course you will learn codes for naming chemicals and drawing circuit diagrams.

Scientists also use a form of 'cut-in-half' code when they draw their equipment. The code makes it easier to draw and understand diagrams of scientific equipment.

The code scientists use for drawing equipment starts by imagining the equipment being cut in half.



Activity: Drawing equipment

What you will need:

- disposable plastic or paper cup
- scissors
- water-soluble marking pen or a soft pencil
- sponge
- sheet of paper.

What you should do:

- 1 Use the scissors to cut the cup in half.

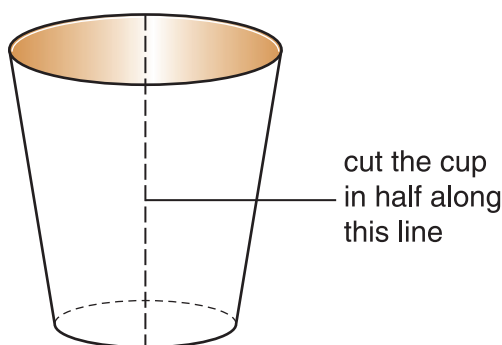

- 2 Use your marking pen to colour the cut edges of the cup.

If you don't have a marking pen, use a soft pencil (a 2B for example). If you use a pencil instead of a marking pen, don't do Step 3 below. Just press the pencil marks onto the paper.

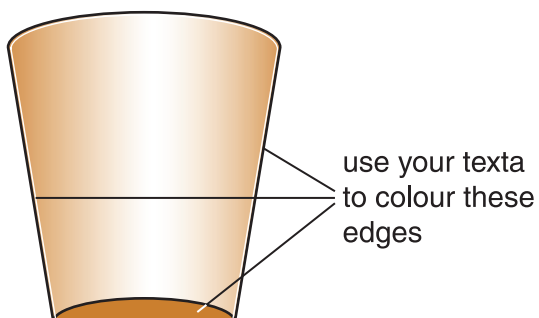

- 3 Use a sponge to spread some water on a sheet of paper. Then press the marking pen coloured edges of the cup down onto the paper. The shape formed on the paper is a scientific drawing of a paper cup.

Does your drawing look like this? Well done! Notice that there is no line across the top of the cup. This means that the top is open.

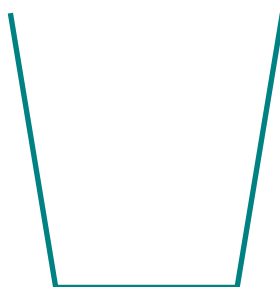

Complete Exercise 1.1: Scientific 'cut-in-half' drawing.

Lesson 2: Scientific drawing of laboratory equipment

There are two drawings of a measuring cylinder below. The drawing on the left is a three-dimensional drawing. It tries to show the full view of the measuring cylinder with length, breadth and depth. The drawing on the right is a two-dimensional drawing or 'cut-in-half' drawing. It shows only the outline of the measuring cylinder.

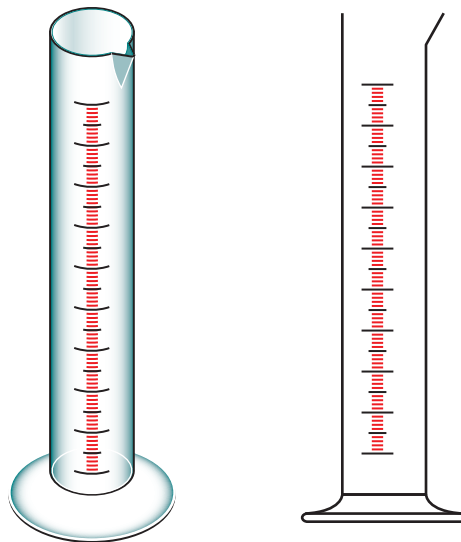

Two views of a measuring cylinder

In the next activity you will use the two views of the measuring cylinder above to answer questions on features of scientific drawings.







Which do you think is the correct scientific drawing of a measuring cylinder? The drawing on the right is the correct scientific drawing.

What are two features of the drawing on the right that qualify it as a *scientific* drawing. Did you notice that the drawing is a 'cut-in-half' drawing. It has no line across the top because the top of the measuring cylinder is open.

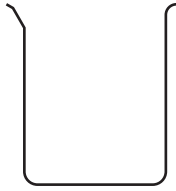
You'll notice that science books, and even your science lessons, don't always have equipment drawn in a scientific way.

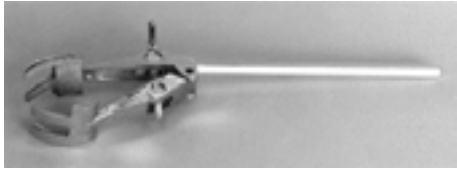
Sometimes it's important to show what equipment really looks like or how different parts fit together, so these drawings are three-dimensional instead of 'cut-in-half'. But whenever possible, scientific equipment is shown as 'cut-in-half' drawings.

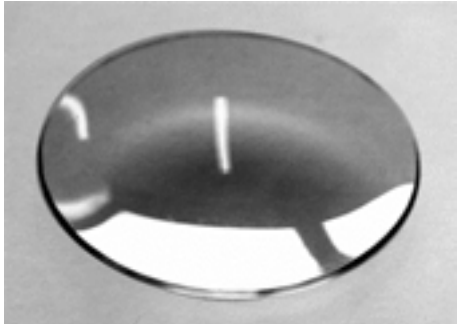
Below are some scientific drawings of common science equipment.

Equipment	What it looks like	Scientific drawing
beaker		
bosshead		
clamp		
clock glass		

conical flask

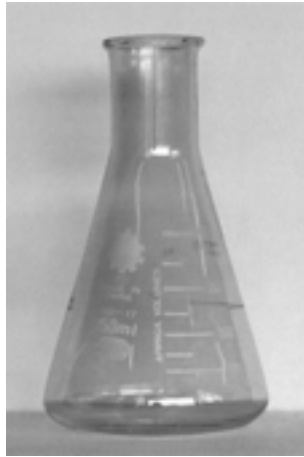

filter funnel

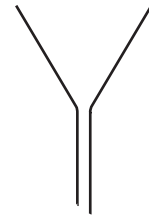
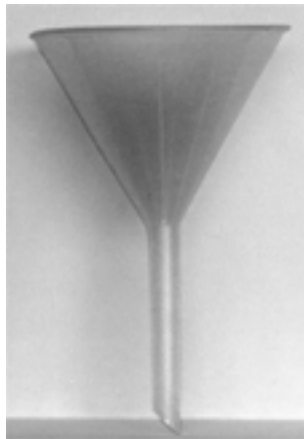

measuring
cylinder

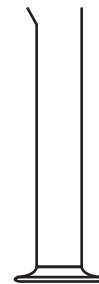
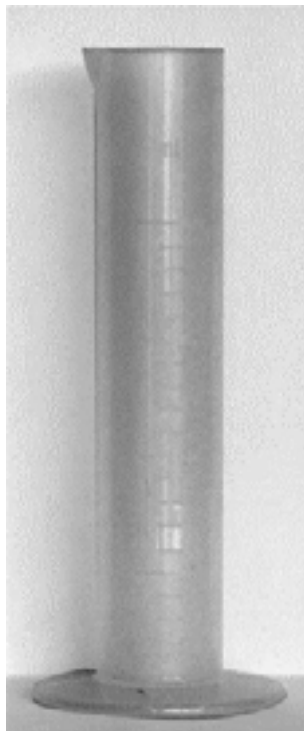

retort stand

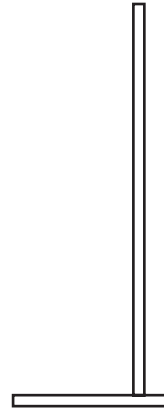

spirit burner



test tube

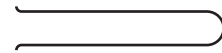
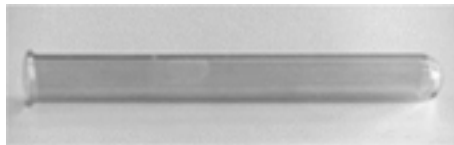

tripod

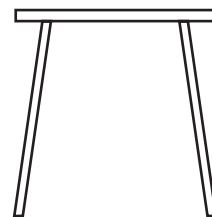

wire gauze

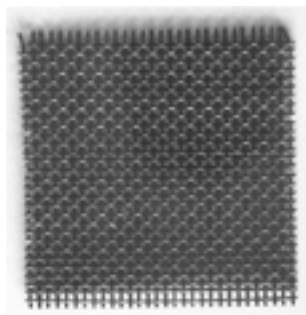

Did you notice that some of the scientific drawings are 'cut-in-half' views while other drawings look very different from the objects they represent? For equipment like a bosshead or gauze, 'cut-in-half' drawings would be even harder and more confusing than three-dimensional drawings. So instead, scientists have made up special symbols to represent objects that are very difficult to draw.

Look through the scientific drawings again. Which ones are 'cut-in-half' views? Which ones are special symbols?

When you are ready, do the next activity to see if you can recognise equipment that is drawn scientifically.



Activity: Recognising equipment

Name each piece of equipment.

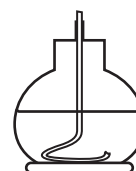
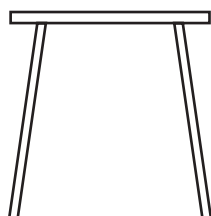
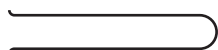

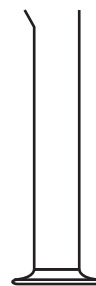
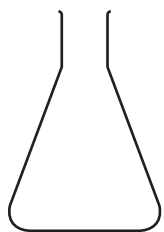

Check your answers.



Activity: Equipment puzzle

How many pieces of equipment can you recognise? List the names of the equipment shown in the drawing.

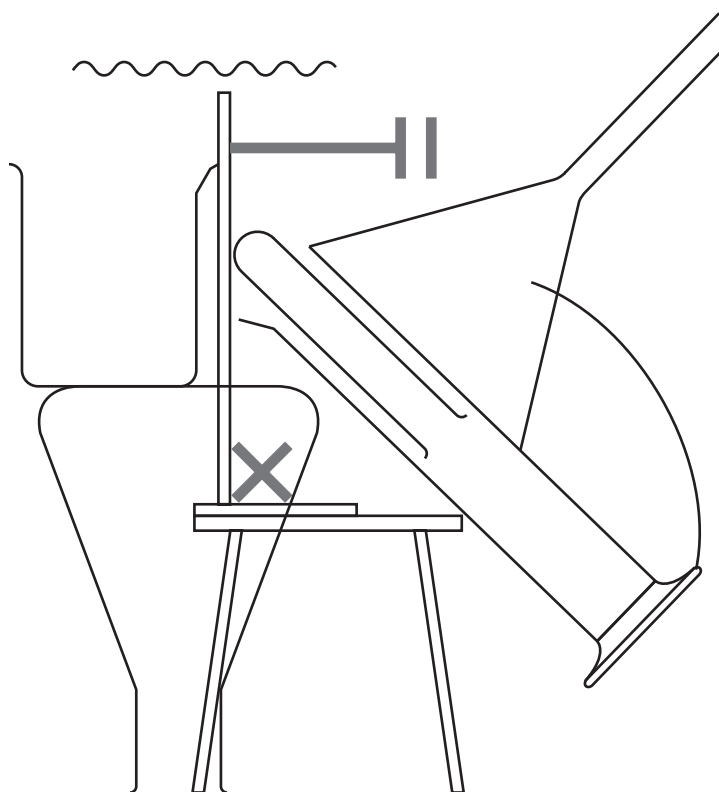

Check your answers.

How many pieces of equipment did you find and name?

10 – 11 Excellent

9 – 7 Very good

6 – 3 Perhaps you should try again?

Less than 3 You need to spend more time identifying equipment!



Complete Exercise 1.2: Selecting the scientific drawing.

Lesson 3: Labelling diagrams

Here is a diagram that shows several different pieces of equipment used to filter a liquid mixture.

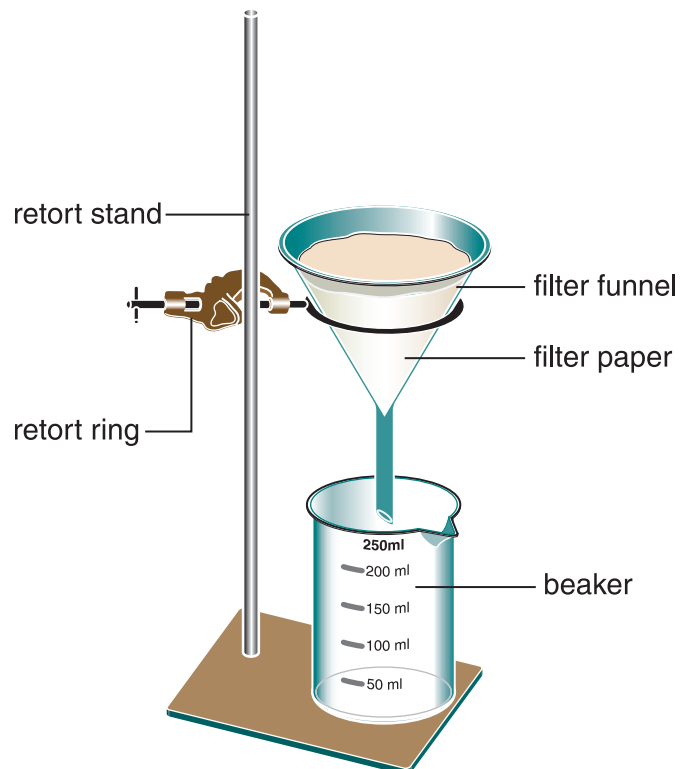

Filtering equipment

What do you notice about the labels on the diagram? Write down your observations about the labels on the diagram.

Did you notice:

- all the labels start with a small letter
- labels are connected to the drawing by straight lines
- the lines are all horizontal (across the page and parallel).

You should try to do all of these things when you label a diagram. Occasionally, lack of space might make it better to draw some lines at an angle. Sometimes it is better to use arrows.

The diagram shows scientific equipment and the labelling is done in a scientific way, but it is not the best way to draw a diagram in science. Remember, scientific diagrams should be drawn as 'cut-in-half' diagrams.



Activity: Labelling a scientific diagram

What you will need:

- pencil
- ruler.

Label these diagrams. Use your pencil and ruler to draw the lines for the labels. Use your pencil to write the labels. See how neat you can be.

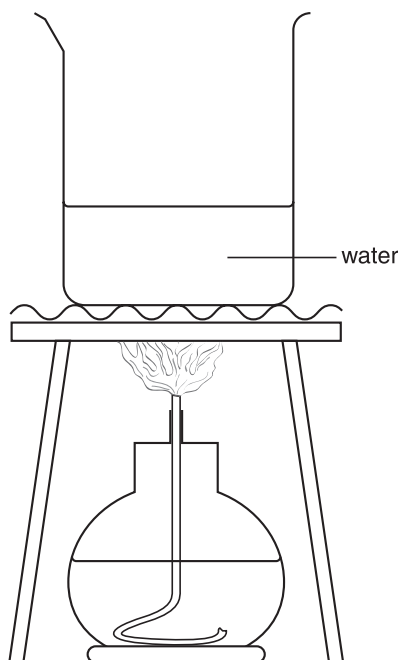

Heating water

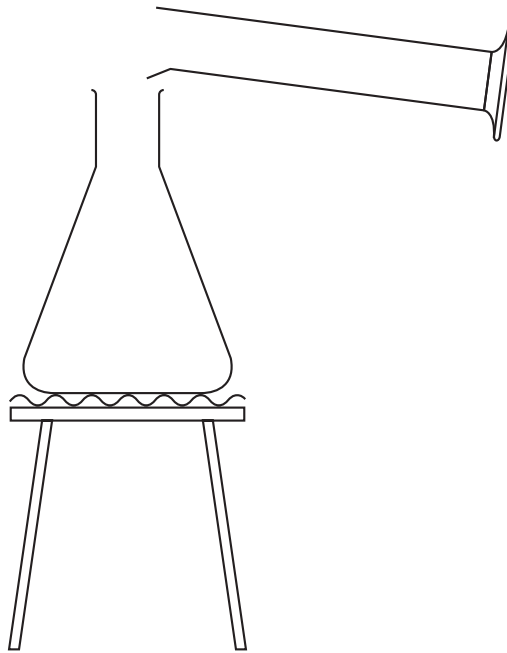

Transferring liquid



Check your answers.



Complete Exercise 1.3: Labelling a scientific diagram.

Lesson 4: Drawing and labelling a scientific diagram



Activity: Drawing a labelled diagram

Draw and label a scientific diagram of the equipment shown in the photograph below. Do your drawing next to the photograph.

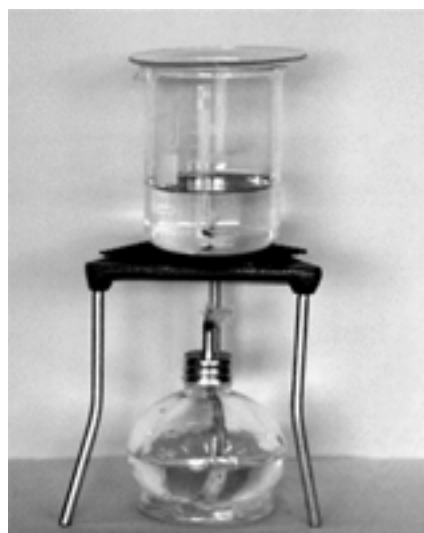

Check your labelled diagram.



Complete Exercise 1.4: Drawing a labelled scientific diagram.

Lesson 5: Computer graphic skills using *MS Word*

This lesson shows you how to use the drawing toolbar feature of *Microsoft Word* to draw scientific equipment.



Using the drawing toolbar

- 1 Go to **View** on the menu bar at the top of the screen.
- 2 Go down the drop-down menu to **Toolbars** and click on **Drawing**. A drawing toolbar should appear towards the top, side or bottom of the screen. Your drawing toolbar should look something like this

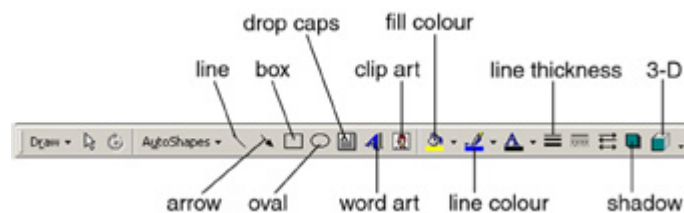

Drawing toolbar (with labels added)

Screen shot of Microsoft Word used by permission from Microsoft Corporation.

Creating a diagram

Freeform drawing is best to use for scientific diagrams. Go to **Autoshapes**, click to obtain the **Lines** menu. Choose the polygon that represents freeform drawing.

In freeform you can draw:

- curved lines by dragging the mouse
- straight lines by clicking the mouse at the start point, move to the end position and click the mouse again
- an open shape by double clicking at the end of the drawing – this is useful for 'cut-in-half' scientific diagrams with openings
- a closed shape by clicking near the start point.



Activity: Drawing items of scientific equipment

Open a new blank document page and use freeform drawing to draw the following pieces of equipment:

- beaker
- test tube
- filter funnel
- tripod
- wire gauze.

Your drawings do not have to be perfect. Save these drawings as later you will learn how to reshape, resize, move and rotate drawings.

Reshaping a diagram

- 1 Double click on a line of your beaker diagram so that the **Format, AutoShape** menu appears.
- 2 Click on **Size** then adjust the height and/or width % figures to reshape.
- 3 Click the **Lock aspect ratio** check box to keep the proportions of height and width constant.
- 4 Reshape the beaker diagram to produce a range of beakers from short and wide to tall and thin.

Moving a diagram

- 1 Click on a line of your test tube diagram.
- 2 Drag the cursor to a new position.

Resizing a diagram

- 1 Click on a line of your filter funnel diagram so that box dots appear.
- 2 Drag on a corner dot (resize handle) inwards and outwards to change the size of the diagram.

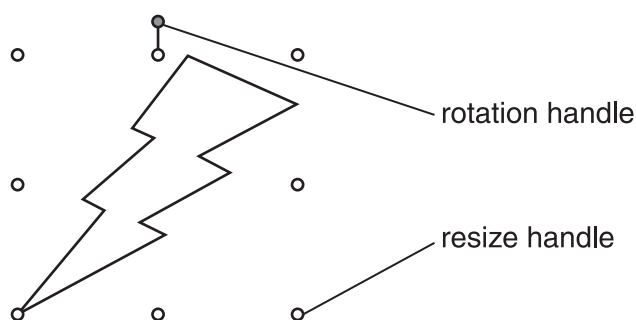

Rotating a diagram

- 1 Click on a line of your tripod diagram so that box dots appear.
- 2 Drag on the coloured rotation handle to rotate the diagram.

Grouping objects

- 1 Select the objects you want to group by holding down the **Shift** key as you click each object (beaker, test tube, filter funnel, tripod and wore gauze).
- 2 Go to the drawing toolbar, click **Draw**, then click **Group**.

Ungrouping objects

- 1 Select the group (your scientific equipment) to ungroup.
- 2 Go to the drawing toolbar, click **Draw** then click **Ungroup**.

If this is one of the first times you have used a graphic drawing program then you probably found that scientific drawings took longer than using a ruler and pencil. However, you can probably already see some advantages in using a graphic skills program. With experience you could find it a more effective way for you to do scientific drawings.



Complete the Exercise 1.5: Scientific drawing of equipment

Suggested answers – Part 1

Activity: Recognising equipment

wire gauze	clamp
test tube	beaker
tripod	spirit burner
conical flask	measuring cylinder

Activity: Equipment puzzle

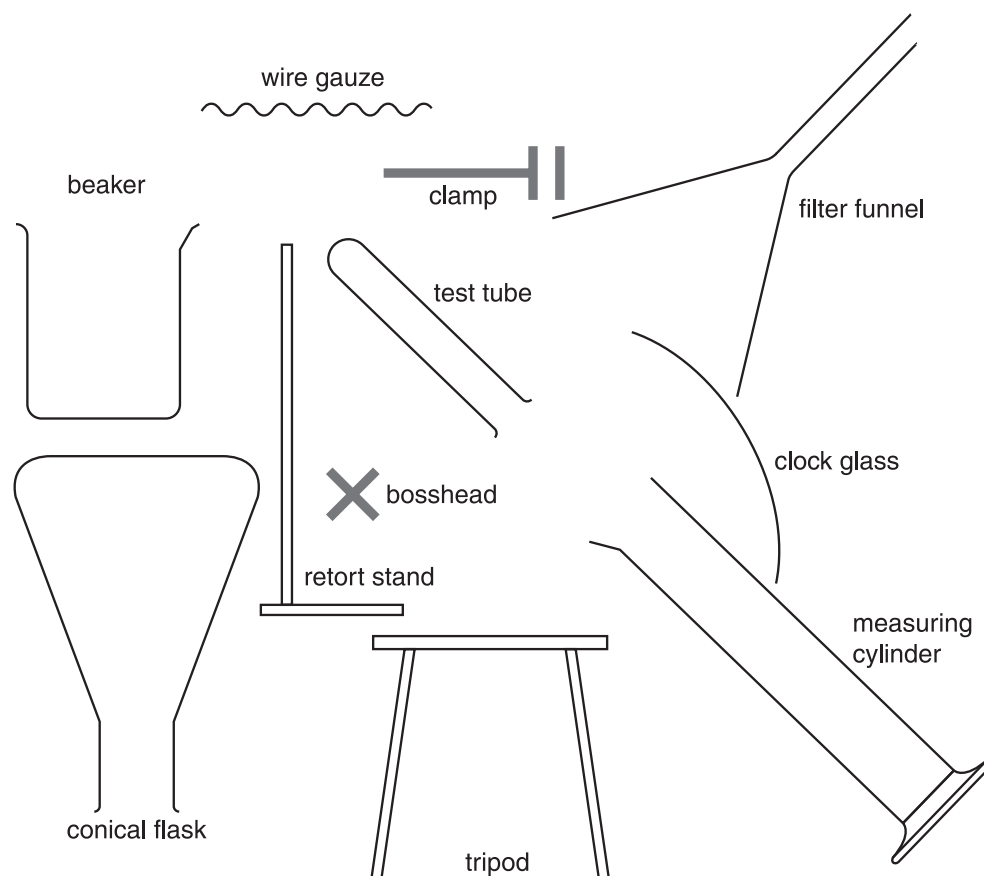

Activity: Labelling a scientific diagram

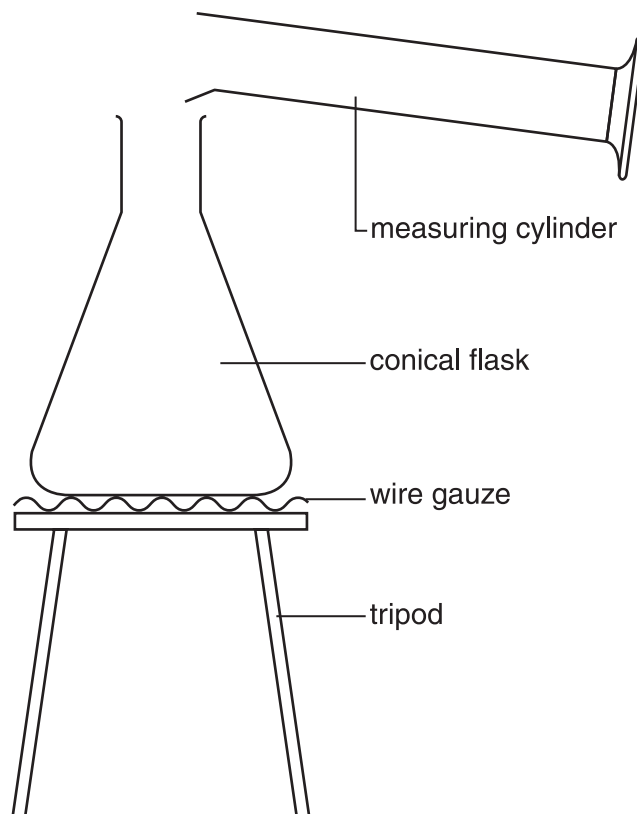
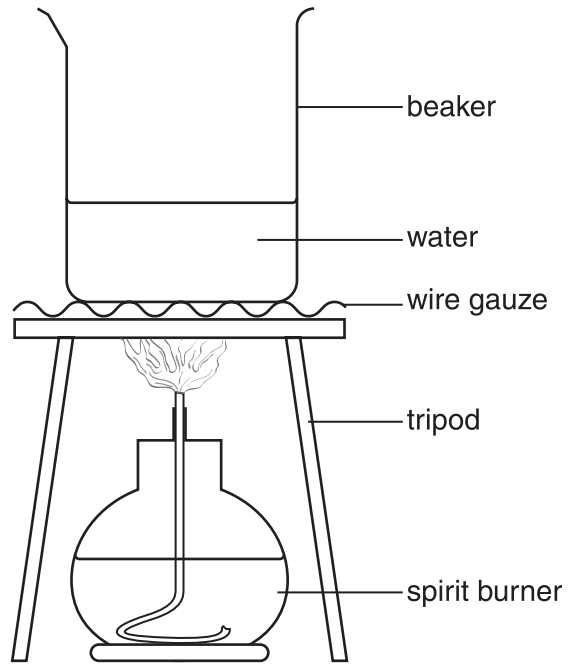

Activity: Drawing a labelled diagram

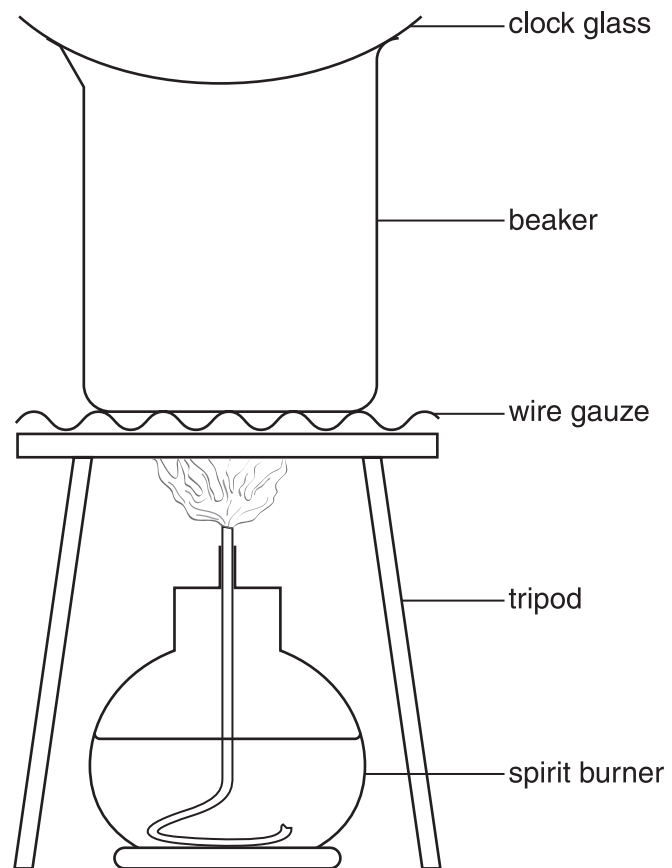

Exercises – Part 1

Name: _____

Teacher: _____

Exercise 1.1: Making a 'cut-in-half' drawing

What you will need:

- an empty milk carton or an empty fruit juice carton
- scissors
- a sponge
- a water-soluble marking pen or a soft pencil.

Make a 'cut-in-half' drawing of the milk or fruit juice carton.

- 1 Use the scissors to cut the carton along the line shown on the diagram below.

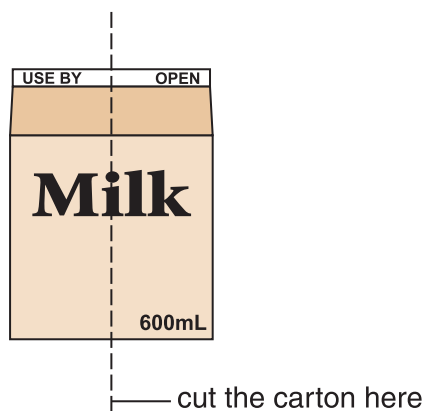

- 2 Use your marking pen or pencil to colour all the edges. If you use a pencil, don't do Step 3 below, just press the pencil marks onto the paper.
- 3 Use a sponge to moisten the back of this page. If the page is not large enough, tape on an extra piece of paper or use paper of your own. Press the coloured edges onto the page.

Exercise 1.2: Selecting the scientific drawing

For each of the four pieces of equipment (beaker, filter funnel, bosshead and tripod) there are three drawings. Choose the correct scientific drawing for each piece of equipment (shown in the photographs).

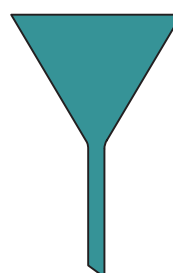
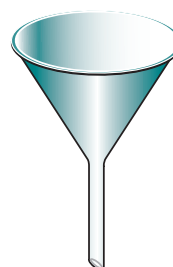
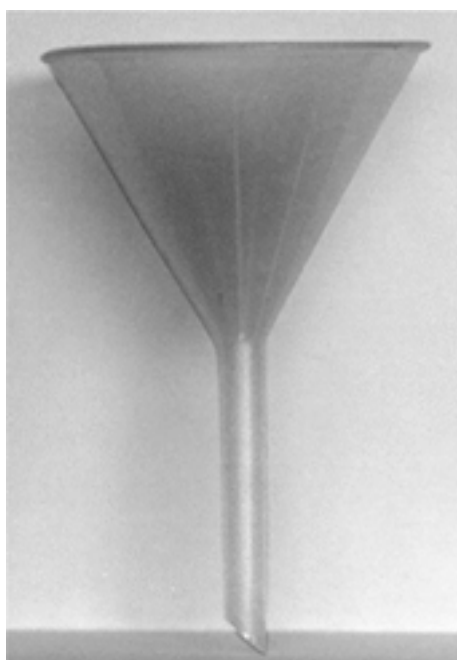
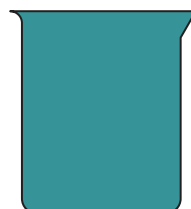
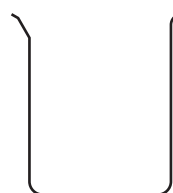
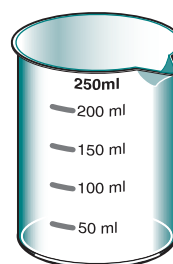
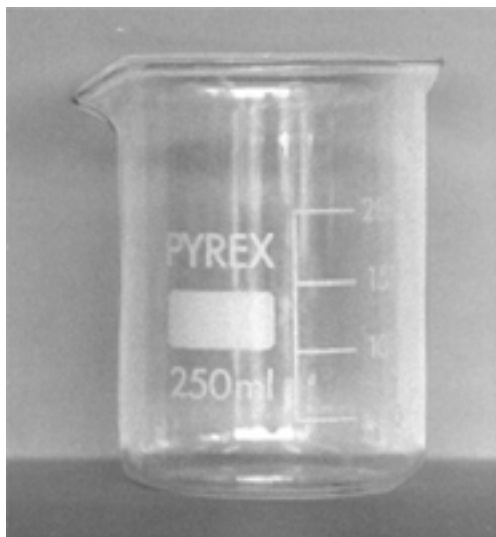

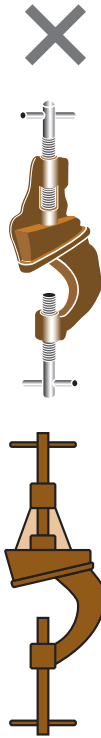

Exercise 1.3: Labelling a scientific diagram

Label the equipment in this diagram. Use your pencil and ruler to draw the lines to the labels. Use your pencil to write the labels.

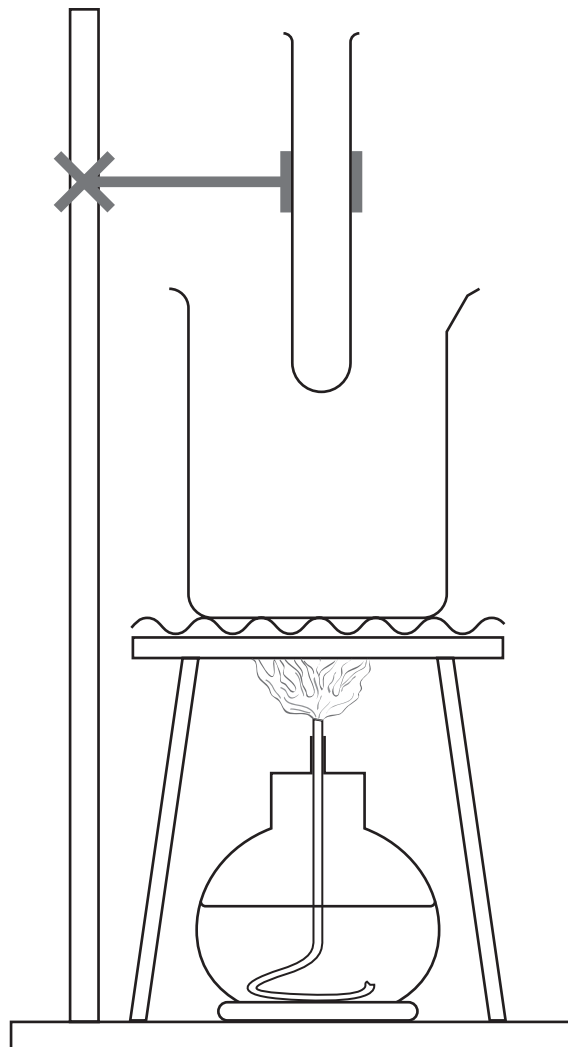

Exercise 1.4: Drawing a labelled scientific diagram

Here is a photograph of some equipment. You can get this equipment and set it up if you wish.

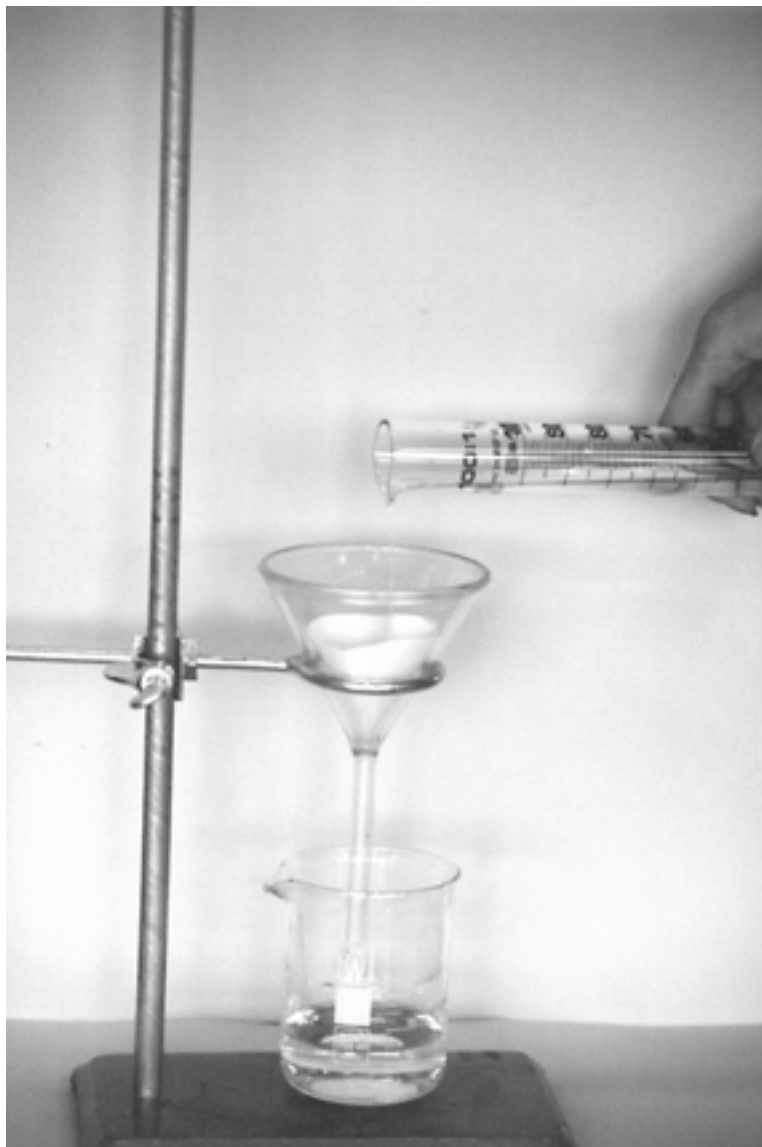

On the next page, draw a labelled scientific diagram of the equipment.

Exercise 1.5: Scientific drawing of equipment

Use a graphics drawing program (such as the drawing toolbar of *Microsoft Word*) to do a scientific drawing of the equipment used for heating a beaker half full of water. You may be able to use some of the drawings you did earlier in this lesson and group them together.

Attach a print out to this page to return to your teacher.